



Preface

The Star Cool AV+ is a system designed to automatically regulate the internal atmosphere of the container using greatly reduced energy consumption compared to manual or other automated fresh air systems.

With a respiring cargo, the container's atmosphere attains the desired gas composition based on entered set points for maximum CO₂, or minimum O₂ via the controller which accurately regulates the exchange of CO₂ for O₂ using ambient air.

While the information herein is assumed to be accurate, Maersk Container Industry AS assumes no responsibility for any errors or omissions that may appear in this documentation.

This manual is valid for:

Model	SCI - X - X - AV+ and SCU - X - X - AV+
Release Date	01.10.2009
Software version:	0301 - 0345

Warnings

Do not operate or maintain this refrigeration unit until you have familiarized yourself completely with the equipment and operating of this unit by reading the instruction in this addendum and the Operating and service manual for Star Cool units.

Do not perform any welding on the unit before disconnecting the power plug.

Disconnect main power supply to unit before inspecting the interior of the controller box.

The unit is charged with R134a and ester oil BSE 55. Do not use any other refrigerant or oil.

Do not use contaminated refrigerant or oil.

Do not release R134a into the atmosphere. Use recovery equipment according to present legislation.

During maintenance please observe that R134a is operating with high and low temperatures in combination with high pressures, which may cause personal injuries if not handled properly.

During recovery and maintenance of R134a unit personal protection equipment has to be worn.

Do not trap any liquid refrigerant inside pipes during soldering work. This may lead to explosion of pipe.

Automatic fresh air ventilation will only be monitored and regulated when the reefer unit is connected and running on AC power. Extended periods of off-power with respiring cargo can be hazardous to the cargo and should be avoided.



Contents

Preface	1
Warnings.....	1
Legend.....	3
AV+ function overview	3
General specification	3
Menu structure	4
Set points	5
Additional menu information for AV+	5
Data Log	6
Components	7
AV+ related alarms.....	7
Other sensor alarms (3XX)	8
Operations alarms (6XX)	9
Communication alarms (7XX)	11
Overall Wiring Schematic	12



Legend

Short name	Name
AirEx mo	Air exchange motor

AV+ function overview

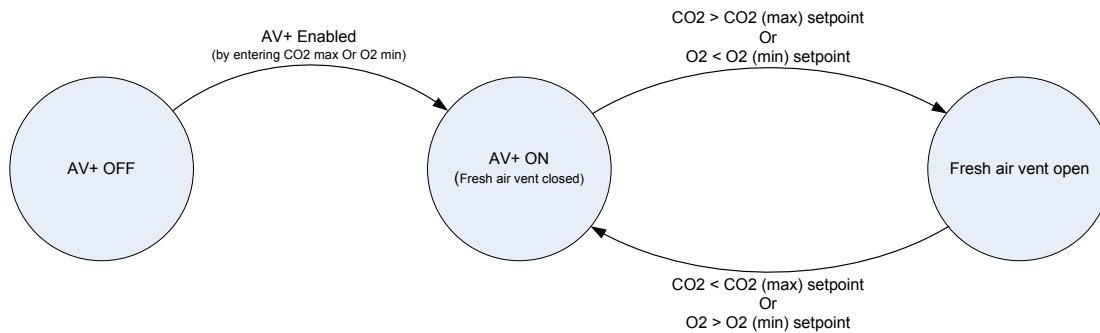

Perishables will generate CO₂ via respiration, leading to an increase in the CO₂ and a proportional decrease in O₂ level inside the container. If the CO₂ level in the container atmosphere reaches above the pre-set CO₂ max level or the O₂ level reaches below the pre-set O₂ minimum level, the air exchange valve will open and thereby lower the CO₂ level and raise in O₂ by diluting with ambient air.

General specification

Additional component to a standard unit:

- CO₂ sensor
- Motor (incl. wiring) in the Air Ex module

Motor

Manufacturer	Bosch
Type	Gear motor
Supply	24VDC

CO₂ sensor

Type	Nondispersive infrared sensor
Operating range	0 - 20%
Accuracy	CO ₂ (5%) +/- 0,3% CO ₂ (0,5%) +/- 0,1%
Supply	22-43V DC
Output	RS-485



Menu structure

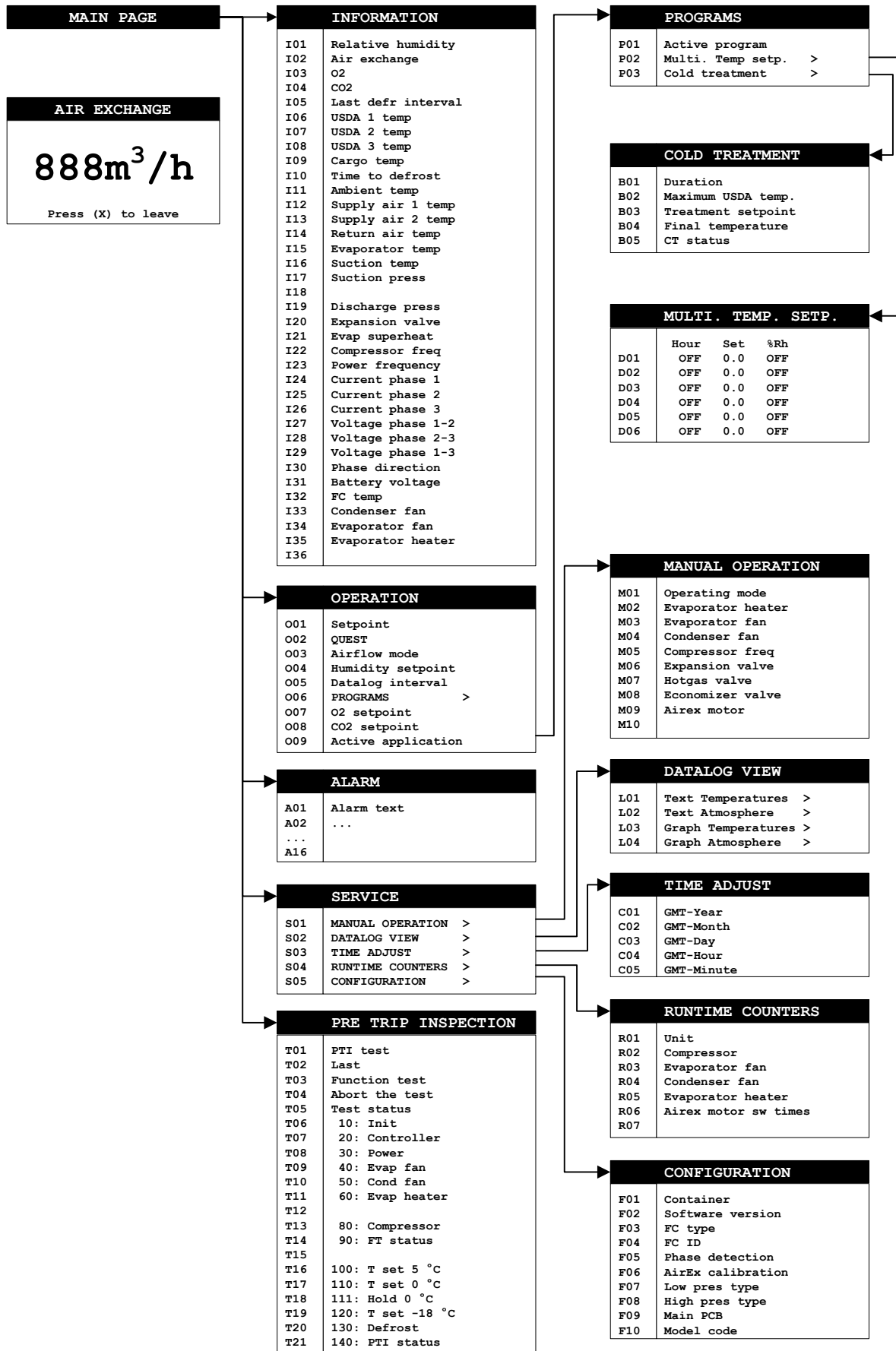



Set points

For AV+ set points are entered via the display: Max CO2 level range 1-12% and minimum O2 range 1-19% or OFF. If O2 is set to OFF, ventilation is solely controlled by CO2 set point, and if CO2 is OFF ventilation is solely controlled by O2 setpoint. The relation between O2 and CO2 in the atmosphere of the container is as illustrated:

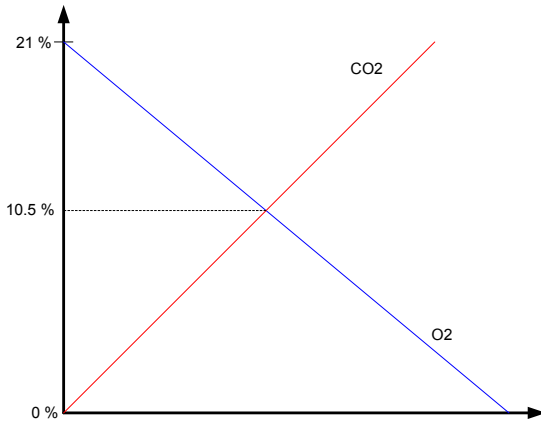

CO2 level is set in O08 and O2 level is set in O07 (See Menu structure).

Additional menu information for AV+

In addition to the standard log this information can be viewed in the log:

I04 CO2 level

Function:

Shows the CO2 level.

Value:

An actual value of the CO2 level inside the container.

O08 CO2 set point

Function:

Max. CO2 (set point.)

Value:

1-12%

I03 O2 level

Function:

Shows the O2 level.

Value:

An calculated value of the O2 level inside the container (21% - CO2 level)

O07 O2 set point

Function:

Min. O2 (set point.)

Value:

1-19% or OFF



Data Log

Title	Info displayed	
CO2Set	CO2 set point	
O2Set	O2 set point	
Input CO2	CO2 level	
Input O2	O2 level	
Control MairPct [%]	0 = air exchange valve closed	100 = air exchange valve open

Locations

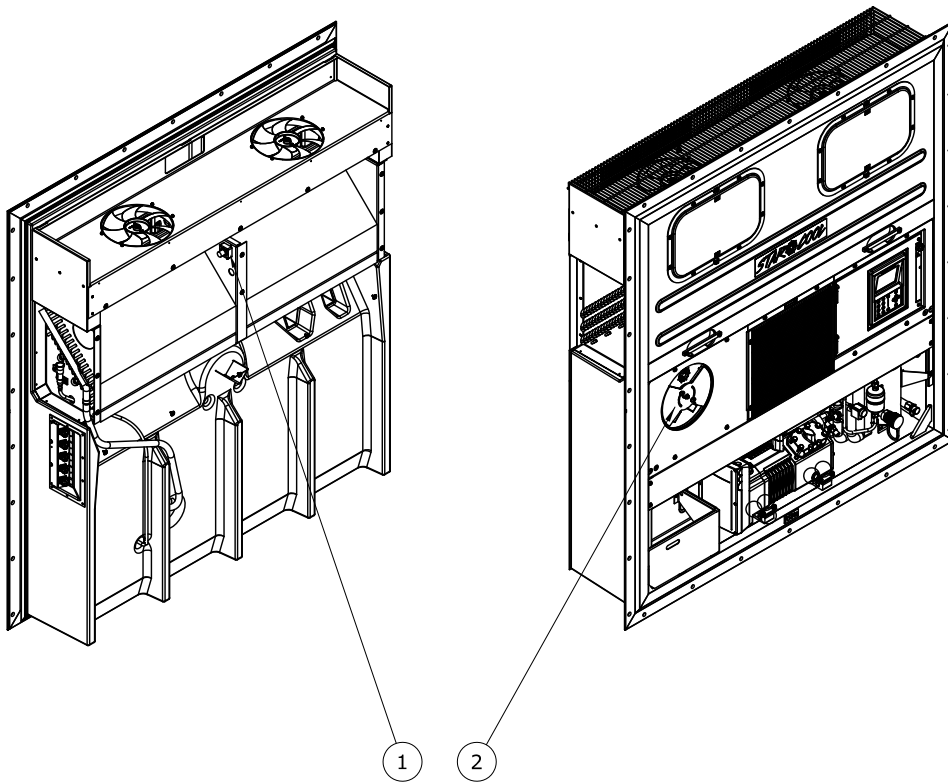

Position	Name
1	CO2 sensor
2	Air exchange module



Components

Air exchange module and CO2 sensor

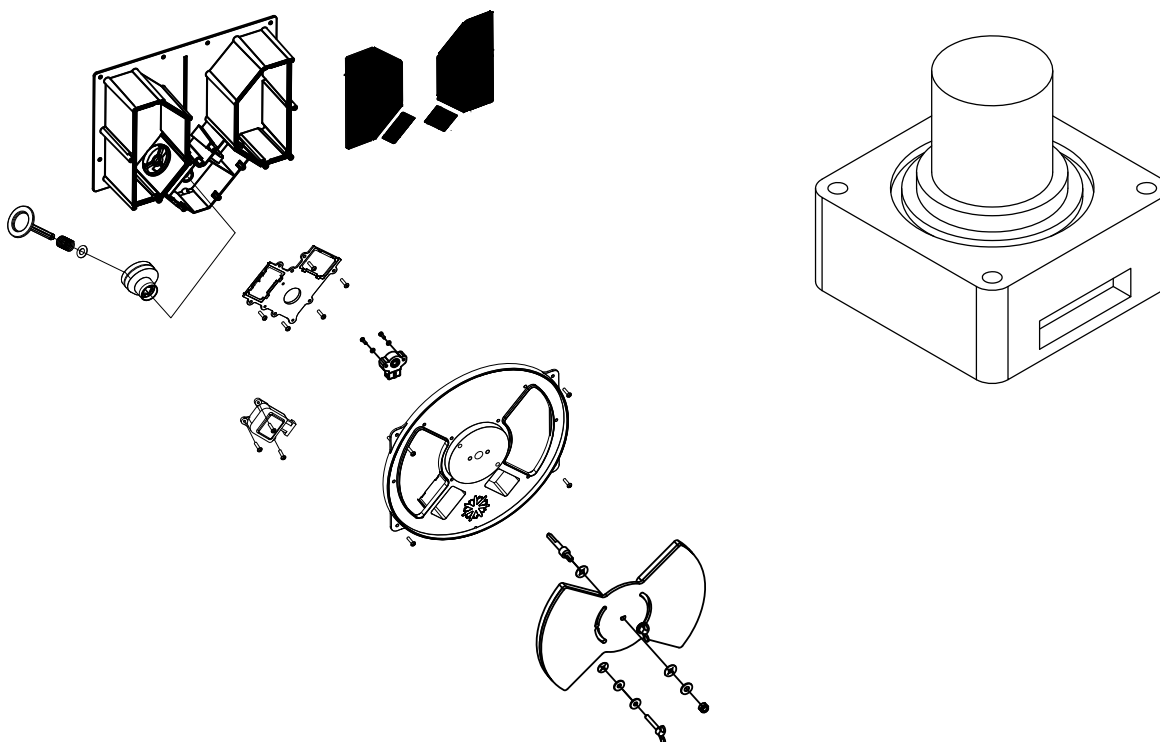

AV+ related alarms

Alarm list:

Id	Display text	Description	Alarm type
3. Other sensor alarms			
310	CO2 invalid	CO2 sensor communication is invalid	Alarm
6. Operations alarms			
607	AirEx open	Air exchange valve open	Fatal Alarm
651	CO2 high	CO2 level is above setpoint +1% for 120 min	Alarm
7. Communication alarms			
740	CO2 sensor missing	Missing or faulty CO2 sensor	Alarm



Other sensor alarms (3XX)

310	CO2 invalid	Alarm			
Description	CO2 sensor communication is invalid				
Cause	Indication of defective CO2 sensor, or lack of connection or defective connection.				
Trouble shooting	<p><u>Possible causes:</u></p> <ul style="list-style-type: none"> • Communication with CO2 sensor broken • Defective CO2 sensor • COMRH cable and or RH-cable is defective • Controller module SMC6 is defective • Values from sensor are invalid <p><u>Accompanied alarms:</u></p> <ul style="list-style-type: none"> • AL 740 <p><u>Trouble shooting:</u></p> <ol style="list-style-type: none"> 1. Verify that cable CO2-com is mounted correctly (and is not damaged) according to wiring diagram inside the controller cabinet. 2. Verify that plugs are properly connected. 3. Verify that there is correct voltage (12V DC) between 1 and 4 on X10. 4. Measure with a multimeter that there is a small DC signal between 2 and 3 on X10, and between 2 and 3 on X75. <ol style="list-style-type: none"> a) If there is no signal: The controller module SMC6 is defective and must be replaced. b) If there is signal: The CO2 sensor is defective and must be replaced. 				
Criteria	Communication with CO2 sensor not possible				
Controller action	None				
	Log	X	Alarm	X	Alarm light Slow flash
Consequence	CO2 level can not be regulated				
Elimination	When sensor value becomes valid, it is marked as inactive in the alarm list and may then be deleted				
Log data	Parm 1	Parm 2	Parm 3	Parm 4	Parm 5
	Active/Inactive	Bytes Gf	Bytes Df		



Operations alarms (6XX)

607	AirEx open					Fatal Alarm
Description	Air exchange valve open in conflict with settings					
Cause	Indication of user having left air exchange open					
Trouble shooting	<p><u>Possible causes:</u></p> <ul style="list-style-type: none"> • Air exchange valve open in freeze mode or AV+ mode • Air exchange open in 50% - 60% RH. • Cable or air exchange sensor defective or not calibrated correctly <p><u>Accompanied alarms:</u></p> <ul style="list-style-type: none"> • Possibly AL 305. <p><u>Trouble shooting:</u></p> <p>1) See and clear error for alarm AL 305.</p> <p>2) Close air exchange. If air exchange is closed, cable for air exchange sensor or sensor is defective see AL 305 for trouble shooting.</p> <p>Calibrate the air exchange sensor (see Controller System Menu decal for air exchange sensor calibration)</p>					
Criteria	Air exchange is open while unit being in the frozen mode, dehumidification with set point below 60%, and or with CA or AV+ running.					
Controller action	None					
	Log	X	Alarm	X	Alarm light	Quick flash
Consequence	Deteriorated control precision					
Elimination	Alarm will be marked as inactive in alarm list when air exchange is closed and may then be deleted.					
Log data	Parm 1	Parm 2	Parm 3	Parm 4	Parm 5	
	Active/Inactive					



651	CO2 high					Alarm
Description	CO2 sensor measures high CO2 level in container					
Cause	Insufficient opening of the air ex. valve					
Trouble shooting	<p>Possible causes:</p> <ul style="list-style-type: none"> Air exchange motor defective CO2 sensor defective <p>Trouble shooting:</p> <ol style="list-style-type: none"> Check valves and air ex module for obstructions Check connections according to wiring schematic Replace CO2 sensor and run air ex manually 					
Criteria	CO2 level > CO2 set point + 0.5 * CO2 set point (and rising)					
Controller action	None					
	Log	X	Alarm	X	Alarm light	X
Consequence	If CO2 is not removed from the container, this will cause damage to the cargo					
Elimination	When sensor value becomes valid, it is marked as inactive in the alarm list and may then be deleted					
Log data	Parm 1	Parm 2	Parm 3	Parm 4	Parm 5	
	Limit	Act	Set point			



Communication alarms (7XX)

740	CO2 sensor missing	Alarm				
Description	CO2 sensor is missing or communication is lost					
Cause	No or bad communication with CO2 sensor					
Trouble shooting	<p><u>Possible causes:</u></p> <ul style="list-style-type: none"> • Communication to CO2 sensor lost • CO2 sensor missing • CO2 sensor defective • COMRH cable and or RH-cable are defective • Main controller defective <p><u>Accompanied alarms:</u></p> <ul style="list-style-type: none"> • AL 302, AL 730, AL 750, AL 751 and AL 760 may accompany this alarm <p><u>Trouble shooting:</u></p> <ol style="list-style-type: none"> 1. If one or more alarms are active, check wires, plugs and connectors. 2. Check voltage supply 12V DC and communication - small AC voltage between 3 and 4 on X10. 3. If only AL 740 active, then check CO2 sensor. Eventually test with another CO2 sensor. 4. If AL 740 is still active, replace controller module SMC6. 					
Criteria	No communication for 2min.					
Controller action	None					
	Log	X	Alarm	X	Alarm light	X
Consequence	Not possible to run AV+					
Elimination	Alarm may be deleted when inactive					
Log data	Parm 1	Parm 2	Parm 3	Parm 4	Parm 5	



Overall Wiring Schematic

Here given in 2 different layouts for Your choice in printing (2 pages for "lay-over" pages, and 1 page suited for A3 printing)

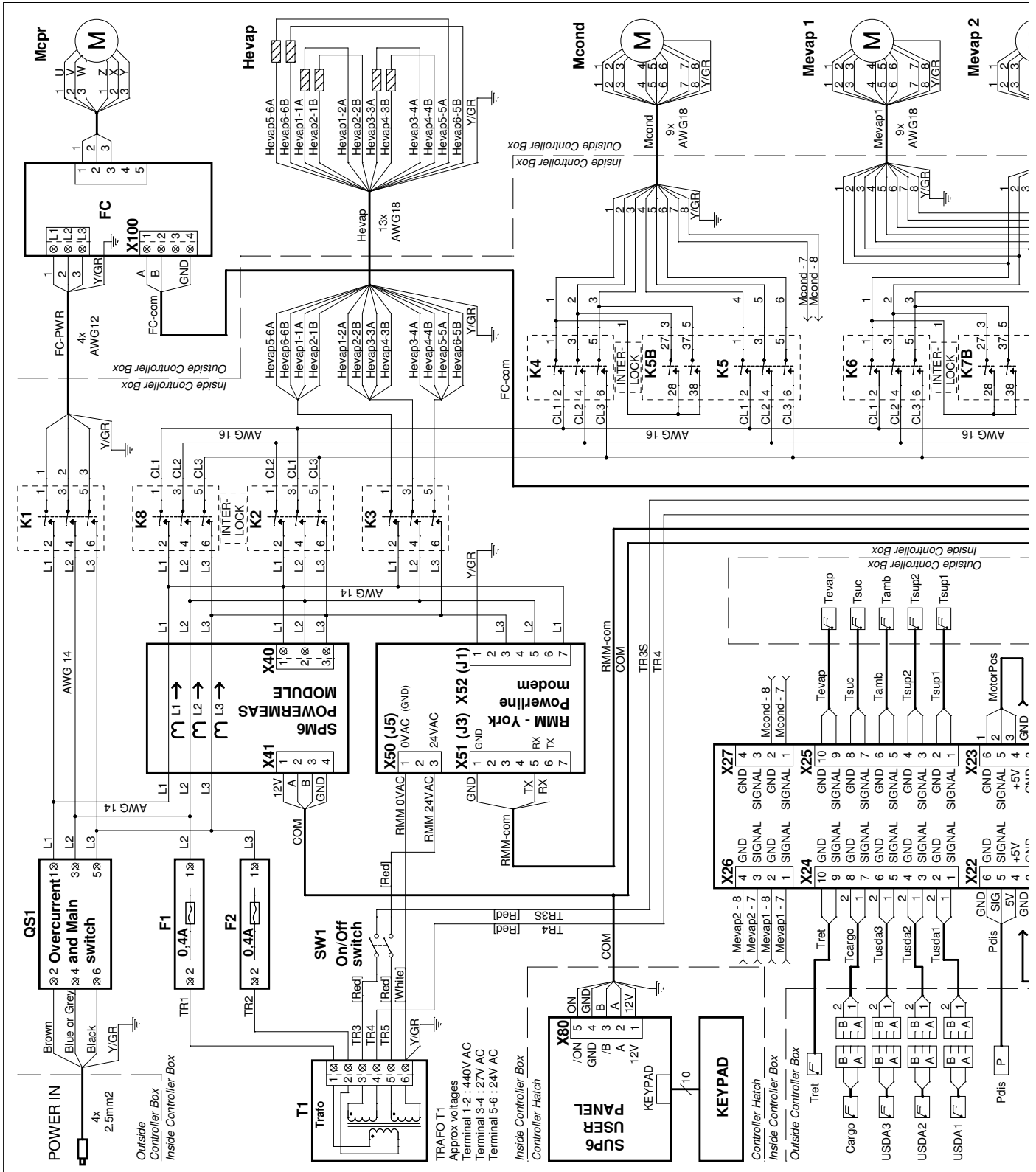

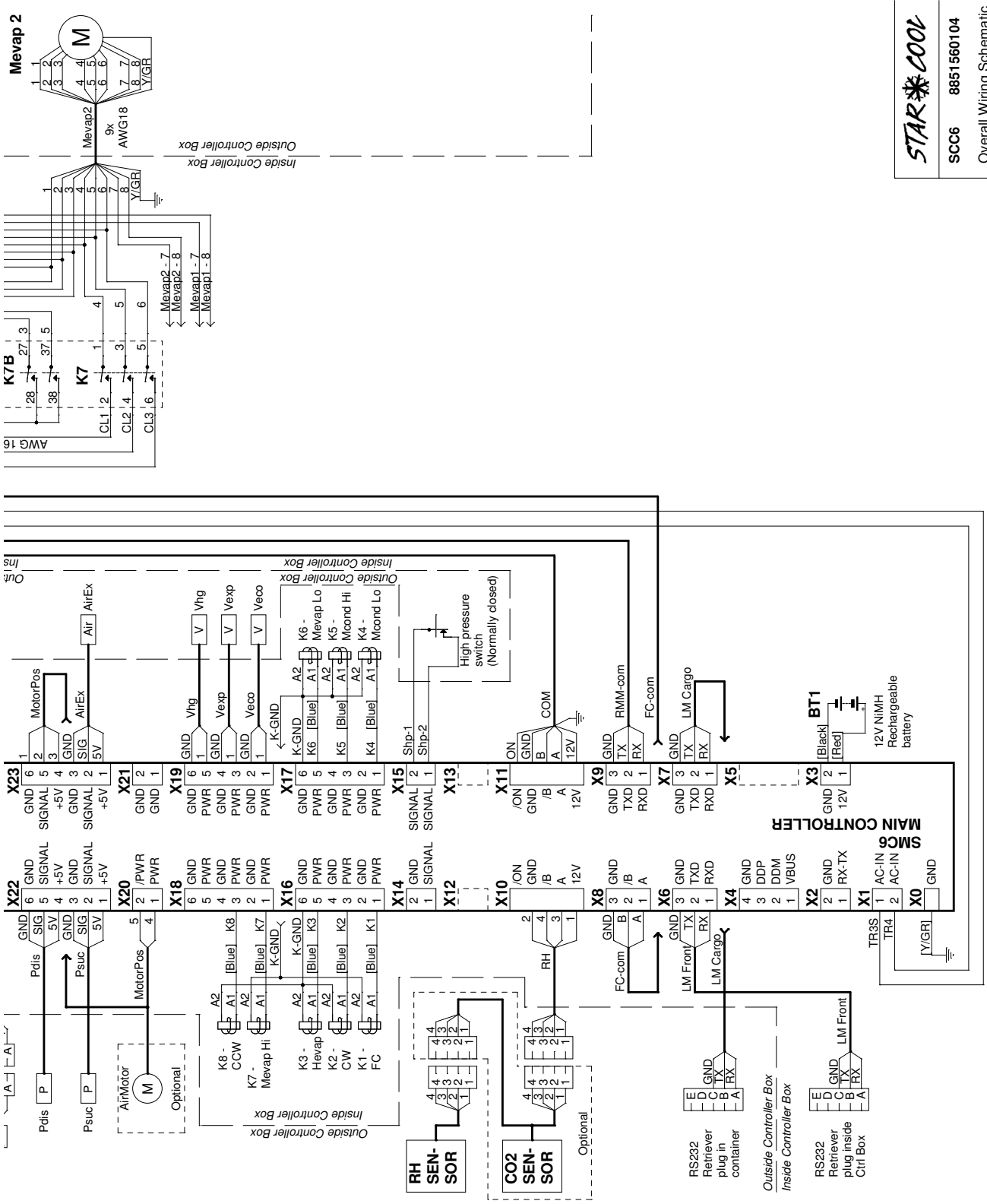

STAR*COOL	
SCC6	8851560104
Overall Wiring Schematic	
Lodam electronics a/s	
P/N: 5251560411 Rev: 1.10	

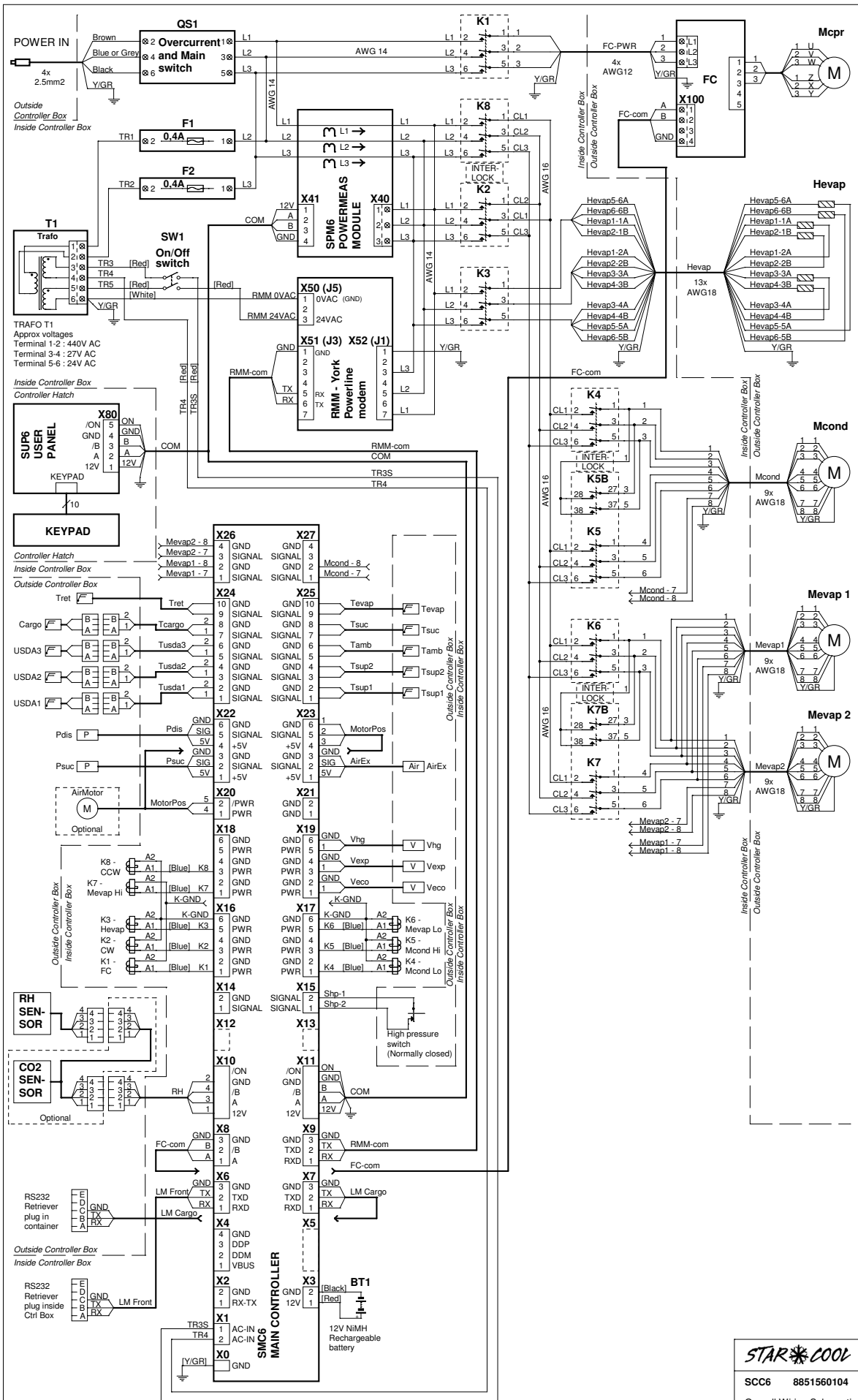

STAR COOL
SCC6 8851560104
 Overall Wiring Schematic
 Lodam electronics a/s
 P/N: 5251560411 Rev. 1.10